

| SPECIFICATIONS                 |                                  |
|--------------------------------|----------------------------------|
| CONTACT CARRIER MATERIAL/COLOR | TPU/BLUE-GRAY                    |
| MOLDED MATERIAL/COLOR          | TPU/BLUE-GRAY                    |
| HOUSING MATERIAL/FINISH        | STAINLESS STEEL/PASSIVATED       |
| CONTACT MATERIAL/PLATING       | BRASS/GOLD                       |
| RATED CURRENT [A]              | 4.0 A                            |
| RATED VOLTAGE [V]              | 250 V                            |
| CABLE JACKET/COLOR             | PVC/GRAY                         |
| CONDUCTOR INSULATION MATERIAL  | FOAMED HDPE (DATA), PVC (POWER)  |
| NUMBER OF CONDUCTORS [AWG]     | 4x22 AWG, 22 AWG DRAIN           |
| SHIELDING                      | FOIL (PAIRS), FOIL (OVERALL)     |
| TEMPERATURE RATING             | -30°C to +80°C (-22°F to +176°F) |
| PROTECTION CLASS               | MEETS NEMA 1,3,4,6P AND IEC IP67 |
| MAX. PANEL THICKNESS           | 3.0 [0.12]                       |

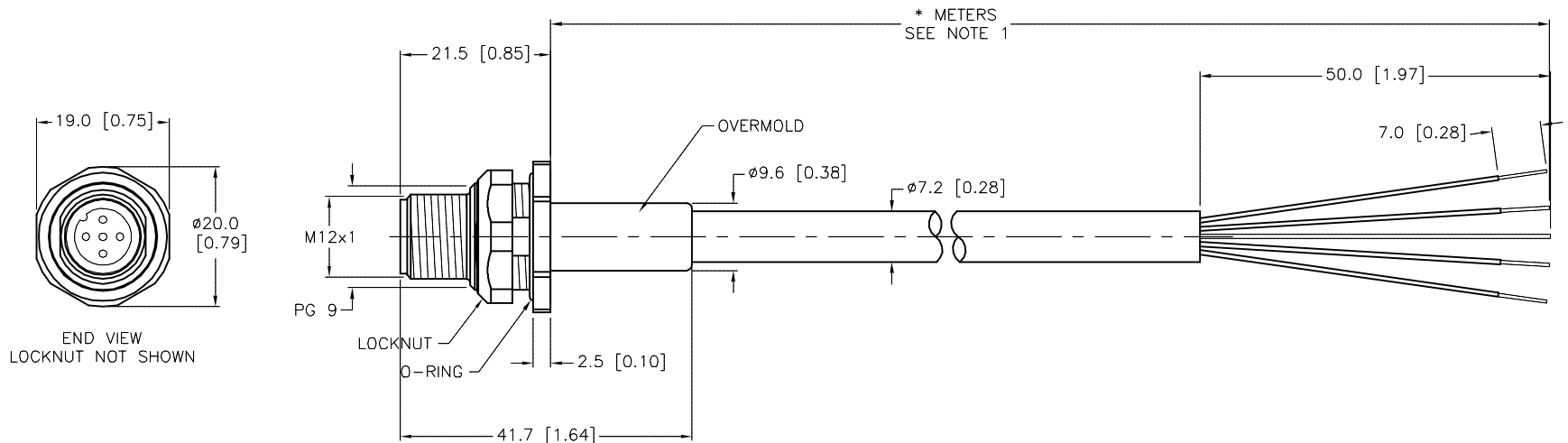
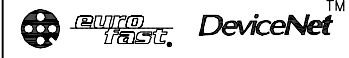

| CABLE LENGTH | TOLERANCE*  |
|--------------|---|
| ALL LENGTHS  | + 4% (OR 50mm) OF LENGTH<br>- 0% (OR 0mm) OF LENGTH<br>WHICHEVER IS GREATER |
| STRIP LENGTH | TOLERANCE*  |
| 0-7mm        | ±0.5mm  |
| 8-29mm       | ±1.0mm  |
| 30-49mm      | ±2.0mm  |
| 50-69mm      | ±3.0mm  |
| 70-100mm     | ±4.0mm  |
| OVER 100mm   | ±5.0mm  |

\* UNLESS OTHERWISE SPECIFIED

SOURCE DRAWING - FOR REFERENCE ONLY

NOTES:  
 1. "\*" INDICATES CABLE LENGTH IN METERS. CONTACT TURCK TO ORDER SPECIFIC LENGTHS.

|   |   |  |             |  |              |
|---|---|--|-------------|--|--------------|
| RELATED DOCUMENTS<br>1.<br>2.<br>3.<br>4. | 3RD ANGLE PROJECTION<br>  | THIS DRAWING IS CONFIDENTIAL AND THE PROPERTY OF TURCK INC. USE OF THIS DOCUMENT WITHOUT WRITTEN PERMISSION IS PROHIBITED. |             | 3000 CAMPUS DRIVE<br>MINNEAPOLIS, MN 55441<br>1-800-544-7769<br>(763) 553-7300<br>(763) 553-0708 fax<br>www.turck.us |              |
|   |   | DRFT   | RDS         | DATE 10/20/03  | DESCRIPTION  |
| MATERIAL                                  | ALL DIMENSIONS DISPLAYED ON THIS DRAWING ARE FOR REFERENCE ONLY | APVD   | SCALE 1=1.0 | F5FDV 572-*M   |              |
| FINISH                                    |   | UNIT OF MEASUREMENT<br><b>MILLIMETER [ INCH ]</b>  |             | IDENTIFICATION NO.   | REV<br>D     |
| D   | UPDATE RATED VOLTAGE  | RDS  | 08/06/19    | 75160  |              |
| REV                                       | DESCRIPTION   | BY   | DATE        | ECO NO.  |              |
| DO NOT SCALE THIS DRAWING                 |   |  |             | FILE: 777005177  | SHEET 1 OF 1 |